

## 1. General Description

---

The EM74LVC32A is a quad 2-input OR gate. Inputs can be driven from either 3.3 V or 5 V devices. This feature allows the use of these devices as translators in mixed 3.3 V and 5 V environments.

Schmitt-trigger action at all inputs makes the circuit tolerant of slower input rise and fall times.

This device is fully specified for partial power down applications using  $I_{OFF}$ . The  $I_{OFF}$  circuitry disables the output, preventing the potentially damaging backflow current through the device when it is powered down.

## 2. Features and Benefits

---

- Wide supply voltage range from 1.2 V to 5.5 V
- Overvoltage tolerant inputs to 5.5 V
- CMOS low power dissipation
- $I_{OFF}$  circuitry provides partial Power-down mode operation
- Latch-up performance exceeds 250 mA
- Direct interface with TTL levels
- Complies with JEDEC standard:
  - JESD8-7A (1.65 V to 1.95 V)
  - JESD8-5A (2.3 V to 2.7 V)
  - JESD8-C (2.7 V to 3.6 V)
  - JESD36 (4.5 V to 5.5 V)
- ESD protection:
  - HBM ANSI/ESDA/JEDEC JS-001 Class 3A exceeds 6000 V
  - CDM ANSI/ESDA/JEDEC JS-002 Class C3 exceeds 2000 V
- Multiple package options

### 3. Ordering Information

Table 1. Ordering information

Type number	Topside marking	Package		
		Name	Description	Quantity
EM74LVC32AD	LVC32A XYYWW	SOP-14L	plastic small outline package; 14 leads; body width 3.9 mm	3000
EM74LVC32APW	LVC32A XYYWW	TSSOP-14L	plastic thin shrink small outline package; 14 leads; body width 4.4 mm	3000

#### MARKING INFORMATION

NOTE: XYYWW = Vendor Code and Date Code.

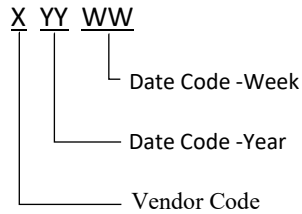

### 4. Function Diagram

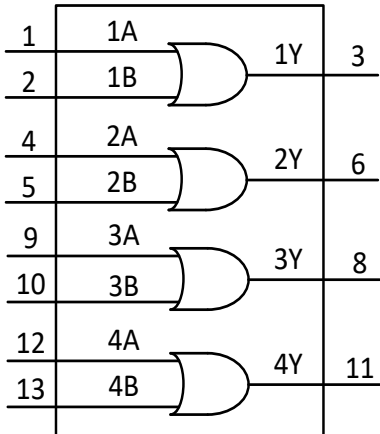
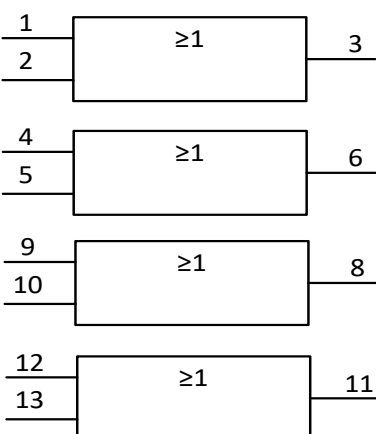
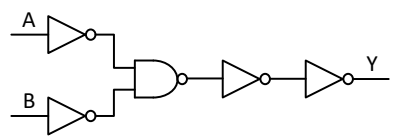
 <p style="text-align: center;">Fig. 1. Logic symbol</p>	 <p style="text-align: center;">Fig. 2. IEC logic symbol</p>	 <p style="text-align: center;">Fig. 3. Logic diagram(one gate)</p>
---	---	--

## 5. Pinning Information

### 5.1. Pinning

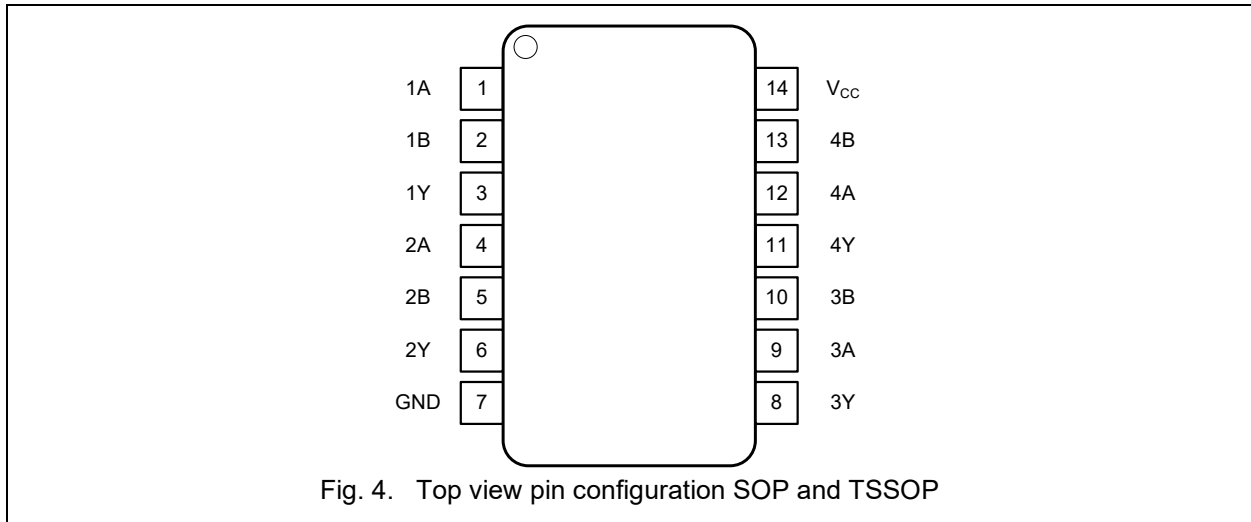

### 5.2. Pin description

Table 2. Pin description

Symbol	Pin	Description
1A, 2A, 3A, 4A	1, 4, 9, 12	Data input
1B, 2B, 3B, 4B	2, 5, 10, 13	Data input
1Y, 2Y, 3Y, 4Y	3, 6, 8, 11	Data output
GND	7	Ground (0V)
V <sub>cc</sub>	14	Supply voltage

## 6. Functional Description

Table 3. Function table

H = HIGH voltage level; L = LOW voltage level; X = don't care.

Input		Output
nA	nB	nY
L	L	L
X	H	H
H	X	H

## 7. Absolute Maximum Ratings

Stresses exceeding the absolute maximum ratings may damage the device. The device may not function or be operable above the recommended operating conditions and stressing the parts to these levels is not recommended. In addition, extended exposure to stresses above the recommended operating conditions may affect device reliability. The absolute maximum ratings are stress ratings only.

**Table 4. Absolute Maximum Ratings**

In accordance with the Absolute Maximum Rating System (IEC 60134). Voltages are referenced to GND.

Symbol	Parameter	Conditions	Min	Max	Unit
V <sub>CC</sub>	supply voltage		-0.5	6.5	V
I <sub>IK</sub>	input clamping current	V <sub>I</sub> < 0 V	-50		mA
V <sub>I</sub>	input voltage	[1]	-0.5	6.5	V
I <sub>OK</sub>	output clamping current	V <sub>O</sub> > V <sub>CC</sub> or V <sub>O</sub> < 0 V		±50	mA
V <sub>O</sub>	output voltage	Active mode [1]	-0.5	V <sub>CC</sub> + 0.5	V
		Power-down mode; V <sub>CC</sub> = 0 V [1]	-0.5	6.5	V
I <sub>O</sub>	output current	V <sub>O</sub> = 0 V to V <sub>CC</sub>		±50	mA
I <sub>CC</sub>	supply current			100	mA
I <sub>GND</sub>	ground current		-100		mA
P <sub>tot</sub>	total power dissipation	T <sub>amb</sub> = -40 °C to + 125 °C		500	mW
T <sub>stg</sub>	storage temperature		-65	150	°C

[1] The input and output voltage ratings may be exceeded if the input and output current ratings are observed.

## 8. Recommended Operating Conditions

The Recommended Operating Conditions table defines the conditions for actual device operation. Recommended operating conditions are specified to ensure optimal performance to the datasheet specifications. EnergyMath does not recommend exceeding them or designing to Absolute Maximum Ratings.

**Table 5. Recommended Operating Conditions**

Symbol	Parameter	Conditions	Min	Max	Unit
V <sub>CC</sub>	supply voltage		1.65	5.5	V
		functional	1.2		V
V <sub>I</sub>	input voltage		0	5.5	V
V <sub>O</sub>	output voltage	Active mode	0	V <sub>CC</sub>	V
		Power-down mode; V <sub>CC</sub> = 0 V	0	5.5	V
T <sub>amb</sub>	ambient temperature		-40	125	°C
Δt/ΔV	Input transition rise and fall rate	V <sub>CC</sub> = 1.65 V to 2.7 V	0	20	ns/V
		V <sub>CC</sub> = 2.7 V to 3.6 V	0	10	ns/V
		V <sub>CC</sub> = 4.5 V to 5.5 V	0	5	ns/V

## 9. Static Characteristics

**Table 6. Static characteristics**

At recommended operating conditions. Voltages are referenced to GND (ground = 0 V).

Symbol	Parameter	Conditions	-40 °C to +85 °C			-40 °C to +125 °C		Unit
			Min	Typ[1]	Max	Min	Max	
V <sub>IH</sub>	HIGH-level input voltage	V <sub>CC</sub> = 1.2 V	1.08			1.08		V
		V <sub>CC</sub> = 1.65 V to 1.95 V	0.65V <sub>CC</sub>			0.65V <sub>CC</sub>		V
		V <sub>CC</sub> = 2.3 V to 2.7 V	1.7			1.7		V
		V <sub>CC</sub> = 2.7 V to 3.6 V	2.0			2.0		V
		V <sub>CC</sub> = 4.5 V to 5.5 V	0.7V <sub>CC</sub>			0.7V <sub>CC</sub>		V
V <sub>IL</sub>	LOW-level input voltage	V <sub>CC</sub> = 1.2 V			0.12		0.12	V
		V <sub>CC</sub> = 1.65 V to 1.95 V			0.35V <sub>CC</sub>		0.35V <sub>CC</sub>	V
		V <sub>CC</sub> = 2.3 V to 2.7 V			0.7		0.7	V
		V <sub>CC</sub> = 2.7 V to 3.6 V			0.8		0.8	V
		V <sub>CC</sub> = 4.5 V to 5.5 V			0.3V <sub>CC</sub>		0.3V <sub>CC</sub>	V
V <sub>OH</sub>	HIGH-level output voltage	V <sub>I</sub> = V <sub>IH</sub> or V <sub>IL</sub>						
		I <sub>O</sub> = -100µA; V <sub>CC</sub> = 1.65 V to 5.5 V	V <sub>CC</sub> - 0.1			V <sub>CC</sub> - 0.1		V
		I <sub>O</sub> = -4 mA; V <sub>CC</sub> = 1.65 V	1.2			1.05		V
		I <sub>O</sub> = -8 mA; V <sub>CC</sub> = 2.3 V	1.9			1.7		V
		I <sub>O</sub> = -12 mA; V <sub>CC</sub> = 2.7 V	2.2			2.05		V
		I <sub>O</sub> = -24 mA; V <sub>CC</sub> = 3.0 V	2.4			2.25		V
		I <sub>O</sub> = -32 mA; V <sub>CC</sub> = 4.5 V	3.8			3.5		V
V <sub>OL</sub>	LOW-level output voltage	V <sub>I</sub> = V <sub>IH</sub> or V <sub>IL</sub>						
		I <sub>O</sub> = 100µA; V <sub>CC</sub> = 1.65 V to 5.5 V			0.10		0.10	V
		I <sub>O</sub> = 4 mA; V <sub>CC</sub> = 1.65 V			0.45		0.65	V
		I <sub>O</sub> = 8 mA; V <sub>CC</sub> = 2.3 V			0.30		0.45	V
		I <sub>O</sub> = 12 mA; V <sub>CC</sub> = 2.7 V			0.40		0.60	V
		I <sub>O</sub> = 24 mA; V <sub>CC</sub> = 3.0 V			0.55		0.80	V
		I <sub>O</sub> = 32 mA; V <sub>CC</sub> = 4.5 V			0.55		0.80	V
I <sub>I</sub>	Input leakage current	V <sub>I</sub> = 5.5 V or GND ; V <sub>CC</sub> = 0 V to 5.5 V		±0.1	±5		±20	µA

## EM74LVC32A

### Quad 2-input OR gate

Symbol	Parameter	Conditions	-40 °C to +85 °C			-40 °C to +125 °C		Unit
			Min	Typ[1]	Max	Min	Max	
$I_{OFF}$	power-off leakage current	$V_{CC} = 0V ; V_I \text{ or } V_O = 5.5 V$		$\pm 0.1$	$\pm 10$		$\pm 20$	$\mu A$
$I_{CC}$	supply current	$V_I = 5.5V \text{ or } GND ; I_O = 0A ; V_{CC} = 1.65V \text{ to } 5.5V$		0.01	10		40	$\mu A$
$\Delta I_{CC}$	additional supply current	per input pin ; $V_{CC} = 2.3V \text{ to } 5.5V ; V_I = V_{CC} - 0.6V ; I_O = 0A$		0.2	500		5000	$\mu A$
$C_I$	input capacitance	$V_{CC} = 3.3V ; V_I = GND \text{ to } V_{CC}$		4				pF

[1]All typical values are measured at  $V_{CC} = 3.3V$  and  $T_{amb} = 25^\circ C$ .

## 10. Dynamic Characteristics

**Table 7. Dynamic characteristics**

Voltages are referenced to GND (ground = 0 V); for test circuit see Fig. 7.

Symbol	Parameter	Conditions	-40 °C to +85 °C			-40 °C to +125 °C		Unit
			Min	Typ[1]	Max	Min	Max	
$t_{pd}$	propagation delay	nA,nB to nY; see Fig. 5 [2]						
		$V_{CC} = 1.2 \text{ V}$		36				ns
		$V_{CC} = 1.65 \text{ V to } 1.95 \text{ V}$	3.4	7.9	22	3.4	22.5	ns
		$V_{CC} = 2.3 \text{ V to } 2.7 \text{ V}$	2.7	4.4	10.5	2.7	11	ns
		$V_{CC} = 3.0 \text{ V to } 3.6 \text{ V}$	2	3.4	7.5	2	8	ns
		$V_{CC} = 4.5 \text{ V to } 5.5 \text{ V}$	1.5	2.6	5	1.5	5.5	ns
$t_{sk(o)}$	output skew time	$V_{CC} = 3.0 \text{ V to } 3.6 \text{ V}$ [3]			1.0		1.5	ns
$C_{PD}$	power dissipation capacitance	per gate ; $V_I = \text{GND to } V_{CC}$ [4]						
		$V_{CC} = 1.65 \text{ V to } 1.95 \text{ V}$		12				pF
		$V_{CC} = 2.3 \text{ V to } 2.7 \text{ V}$		13				pF
		$V_{CC} = 3.0 \text{ V to } 3.6 \text{ V}$		14				pF
		$V_{CC} = 4.5 \text{ V to } 5.5 \text{ V}$		16				pF

[1] Typical values are measured at  $T_{amb} = 25 \text{ °C}$  and  $V_{CC} = 1.2 \text{ V}, 1.8 \text{ V}, 2.5 \text{ V}, 3.3 \text{ V}$  and  $5.0 \text{ V}$  respectively.

[2]  $t_{pd}$  is the same as  $t_{PLH}$  and  $t_{PHL}$ .

[3] Skew between any two outputs of the same package switching in the same direction. This parameter is guaranteed by design.

[4]  $C_{PD}$  is used to determine the dynamic power dissipation ( $P_D$  in  $\mu\text{W}$ ).

$P_D = C_{PD} \times V_{CC}^2 \times f_i \times N + \Sigma(C_L \times V_{CC}^2 \times f_o)$  where:

$f_i$  = input frequency in MHz;

$f_o$  = output frequency in MHz;

$C_L$  = output load capacitance in pF;

$V_{CC}$  = supply voltage in V;

$N$  = number of inputs switching;

$\Sigma(C_L \times V_{CC}^2 \times f_o)$  = sum of outputs.

### 10.1. Waveforms and test circuit

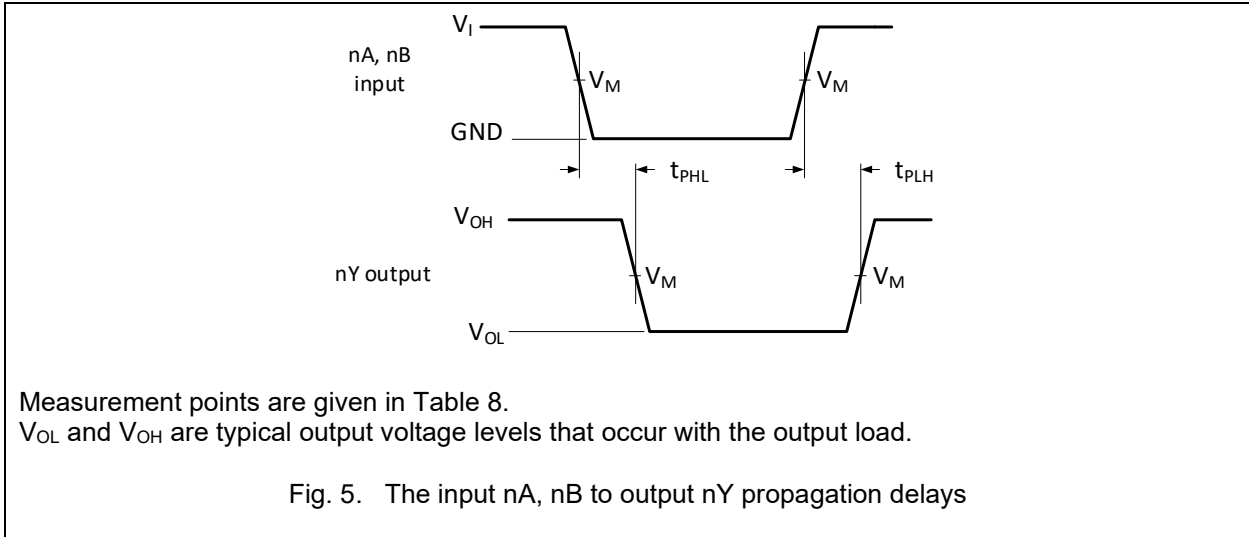
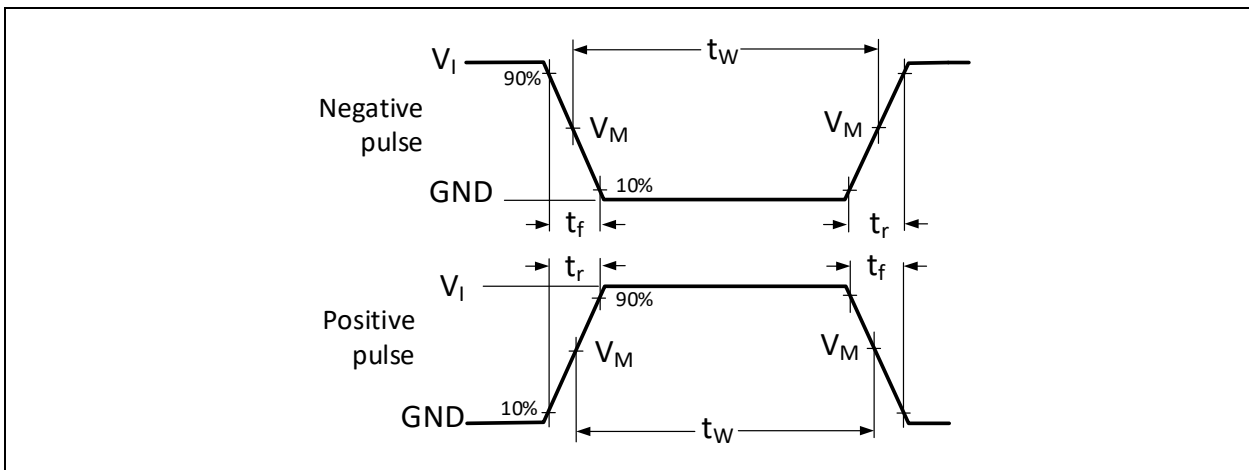

Table 8. Measurement points

Supply voltage	Input	Output
$V_{CC}$	$V_M$	$V_M$
1.2 V	$0.5V_{CC}$	$0.5V_{CC}$
1.65 V to 1.95 V	$0.5V_{CC}$	$0.5V_{CC}$
2.3 V to 2.7 V	$0.5V_{CC}$	$0.5V_{CC}$
3.0 V to 3.6 V	1.5 V	1.5 V
4.5 V to 5.5 V	$0.5V_{CC}$	$0.5V_{CC}$



# EM74LVC32A

## Quad 2-input OR gate

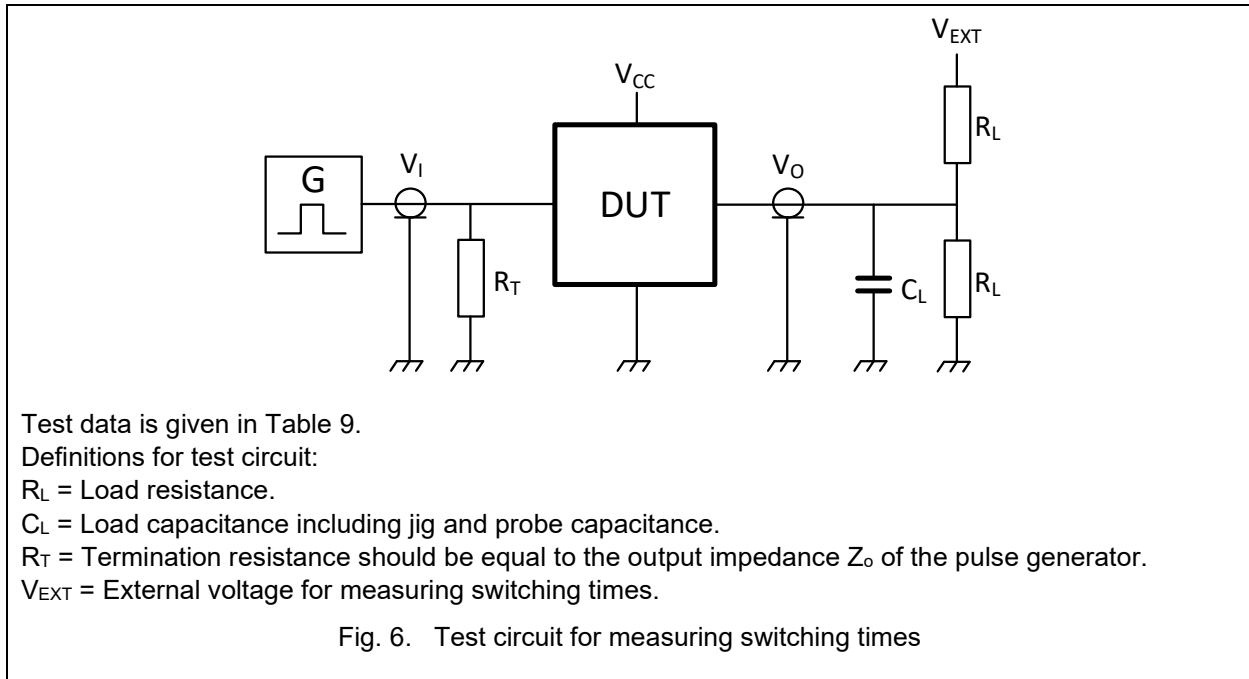
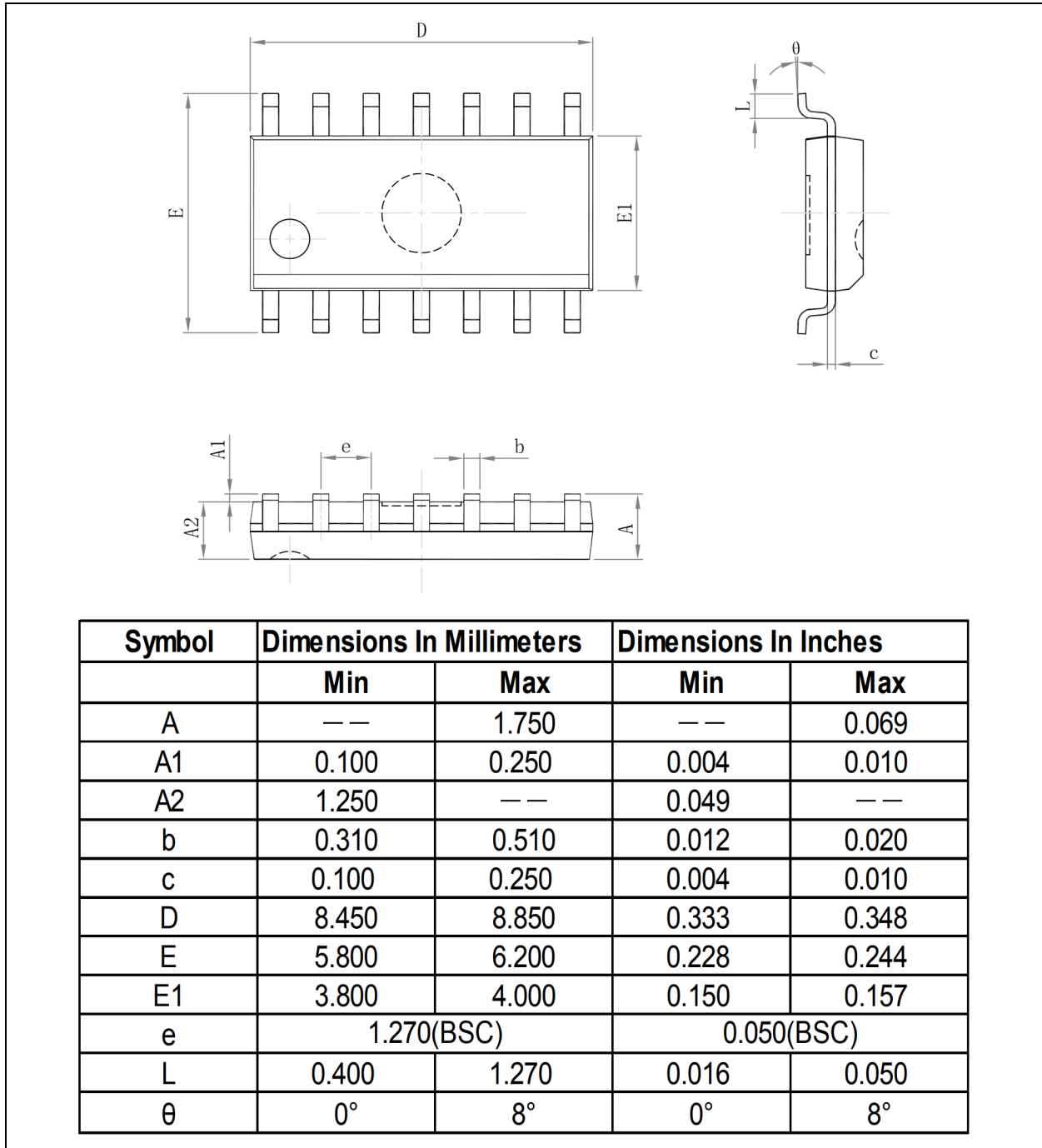

**Table 9. Test data**

Supply voltage	Input		Load		$V_{EXT}$
$V_{CC}$	$V_i$	$t_r = t_f$	$C_L$	$R_L$	$t_{PLH}, t_{PHL}$
1.2 V	$V_{CC}$	$\leq 2.0$ ns	15 pF	500 $\Omega$	open
1.65 V to 1.95 V	$V_{CC}$	$\leq 2.0$ ns	15 pF	500 $\Omega$	open
2.3 V to 2.7 V	$V_{CC}$	$\leq 2.0$ ns	15 pF	500 $\Omega$	open
3.0 V to 3.6 V	3 V	$\leq 2.0$ ns	15 pF	500 $\Omega$	open
4.5 V to 5.5 V	$V_{CC}$	$\leq 2.0$ ns	15 pF	500 $\Omega$	open

# 11. Package Outline

SOP-14L



TSSOP-14L

**EM74LVC32A**

Quad 2-input OR gate

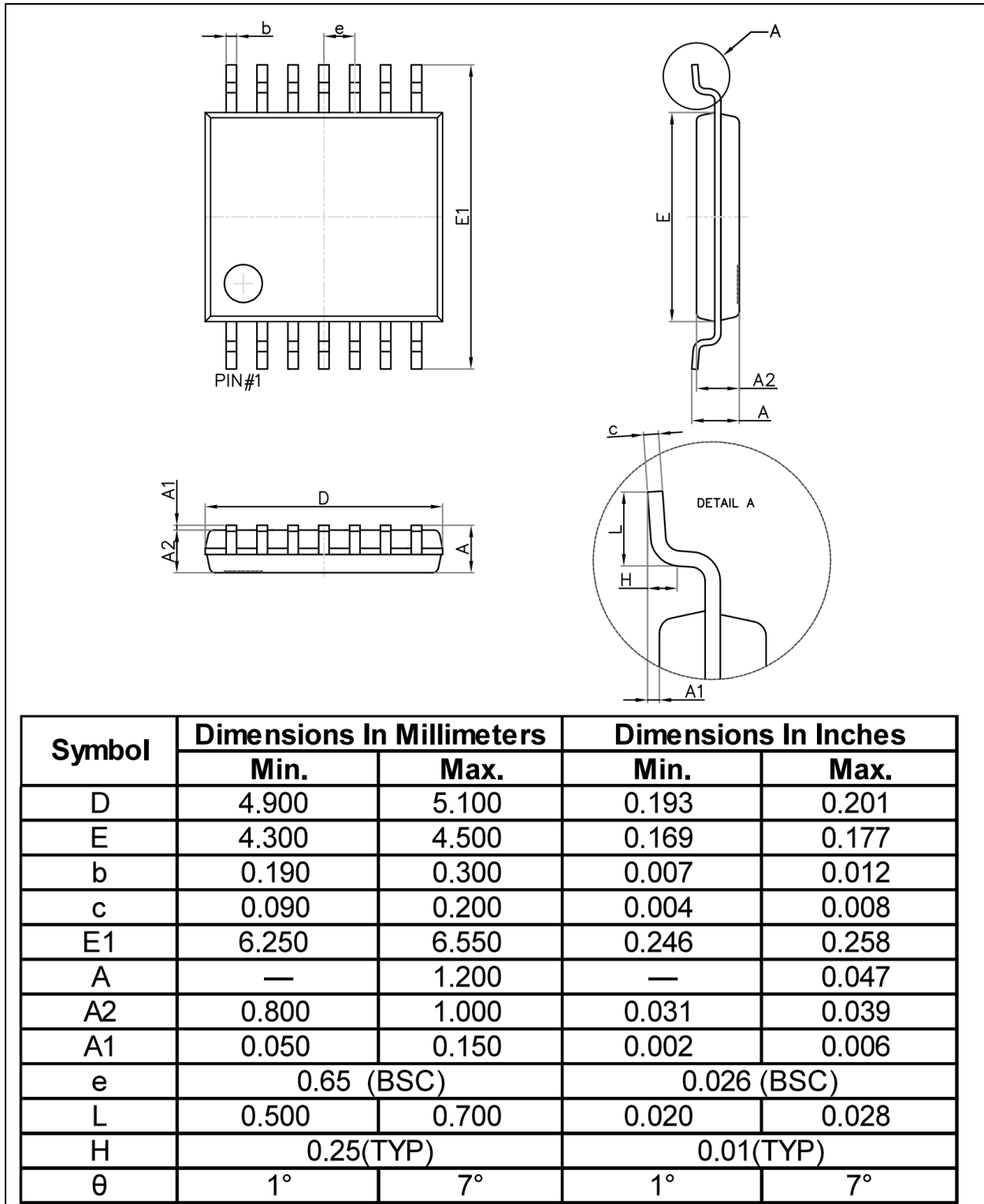

## 12. Tape and Reel Information

### 12.1. Carrier tape dimensions

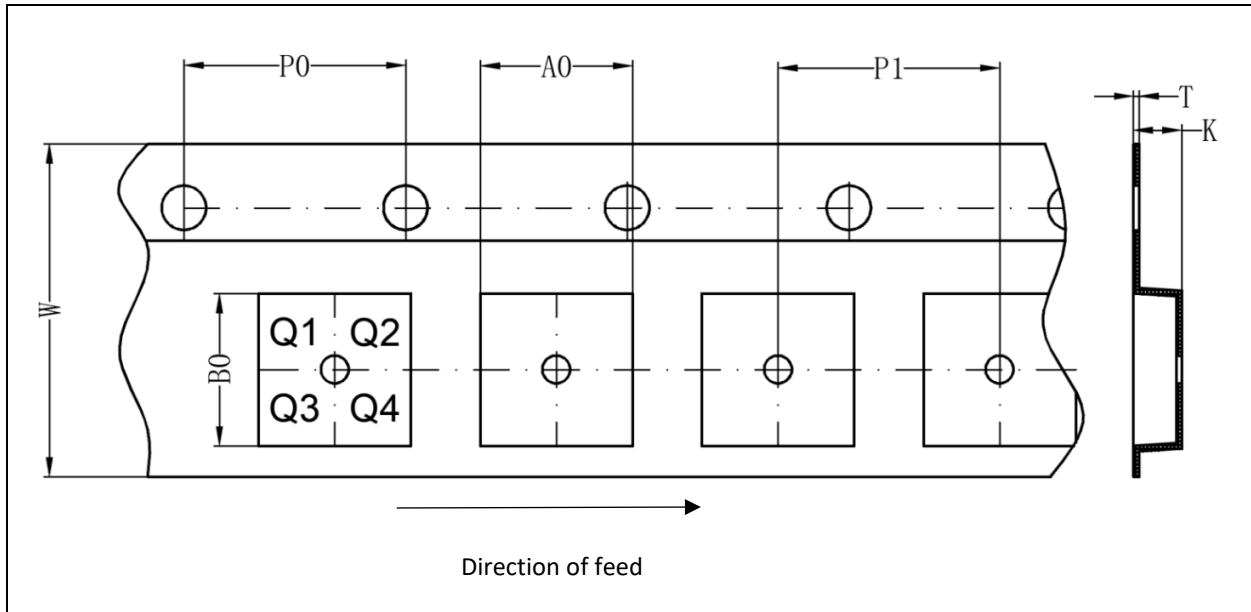

Table 10. Carrier tape dimensions

Package version	A0(mm)	B0(mm)	K0(mm)	T(mm)	P1(mm)	W(mm)	P0(mm)	PIN 1
SOP-14L	6.35	9.1	1.9	0.22	8	16	4	Q1
TSSOP-14L	6.7	5.45	1.6	0.25	8	12	4	Q1

## 12.2. Reel and box dimensions

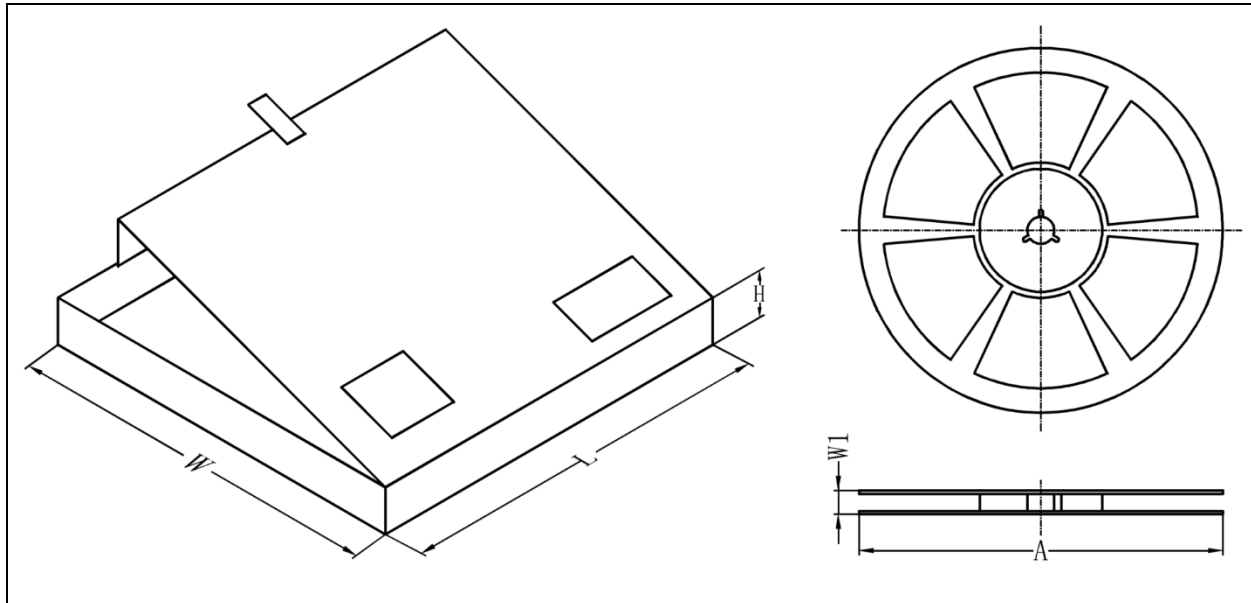

Table 11. Dimensions and quantities

Package version	Type NO. ending	Reel Dimension A (mm)	Reel Width W1 (mm)	MPQ (pcs)	Reels per box	Outer box dimensions L×W×H(mm)
SOP-14L	D	330	22.4	3000	1	358x340x50
TSSOP-14L	PW	330	18.4	3000	1	358x340x50

## 13. Abbreviations

**Table 12. Abbreviations**

Acronym	Description
CMOS	Complementary Metal-Oxide Semiconductor
DUT	Device Under Test
ESD	ElectroStatic Discharge
HBM	Human Body Model
CDM	Charged Device Model
TTL	Transistor-Transistor Logic

## 14. Revision History

**Table 13. Revision history**

Document ID	Release Date	Data sheet status	Change notice	Supersedes
EM74LVC32A Rev. 1.3	Nov 05, 2025	Product datasheet		EM74LVC32A Rev. 1.2
Modifications:	<ul style="list-style-type: none"> <li>Table 5 updated.</li> <li>Section 12 added tape and reel information.</li> </ul>			
EM74LVC32A Rev. 1.2	Dec 15, 2025	Product datasheet		EM74LVC32A Rev. 1.1
Modifications:	<ul style="list-style-type: none"> <li>Table 1: Added topside marking information.</li> </ul>			
EM74LVC32A Rev. 1.1	Aug 30, 2024	Product datasheet		EM74LVC32A Rev. 1.0
Modifications:	<ul style="list-style-type: none"> <li>Table 6: <math>V_{OH}</math> and <math>V_{OL}</math> updated.</li> <li>Table 7: <math>t_{pd}</math> and <math>C_{pd}</math> updated.</li> </ul>			
EM74LVC32A Rev. 1.0	Oct 30, 2023	Product datasheet		